

Ion temperature measurements in the tokamak scrape-off layer

M. Kočan^a, R. Pánek^{b,*}, J. Stöckel^b, M. Hron^b, J.P. Gunn^c, R. Dejarnac^b

^a Department of Experimental Physics, Comenius University, Mlynska dolina F-2, SK-84248 Bratislava, Slovakia

^b Institute of Plasma Physics, Association EURATOM-IPP.CR, Za Slovankou 3, CZ-18200 Prague, Czech Republic

^c Association EURATOM-CEA/DSM/DRFC, Centre de Cadarache, F-13108 Saint Paul Lez Durance, France

Abstract

The ion temperature is a particularly important but rarely measured plasma boundary quantity. In this work we introduce a new electric probe, the segmented tunnel probe (STP), which measures ion temperature, electron temperature, and parallel ion current density simultaneously and with high temporal resolution. The probe was built and tested in the CASTOR tokamak. The STP was operated in a Mach-probe arrangement in a DC mode, providing bi-directional measurements with the temporal resolution of 1 μ s. Therefore, it has significant potential to be employed in the research of transient phenomena in tokamaks (e.g. turbulence, fluctuations and ELMs). We present radial profiles of the plasma parameters in the CASTOR tokamak measured by the STP, using calibrations from particle-in-cell simulations.

© 2007 Elsevier B.V. All rights reserved.

PACS: 52.55.Fa; 52.70.-m; 52.65.Rr

Keywords: Edge plasma; Probes; Sheath

1. Introduction

The ion temperature, T_i , in the tokamak scrape-off layer (SOL) is notoriously difficult to measure and thus rarely available. Spectroscopic measurements cannot yield T_i directly since the hydrogenic ions do not emit photons. Although ion sensitive probes with high spatial and/or temporal resolution have been developed [1,2], it takes considerable theoretical effort to interpret the data correctly. The most elaborated of them, the retarding field energy analyzer (RFA) [3], access ion and electron

velocity distributions directly, but is intrinsically limited in time resolution. In addition, RFA does not allow simultaneous measurements of ion and electron temperatures.

This work describes a new Langmuir probe, the segmented tunnel probe (STP), that measures parallel ion and electron temperatures, and parallel ion current density simultaneously with high temporal and spatial resolution. Here we focus primarily on the measurements of ion temperature.

The paper is organized as follows: In Section 2 the STP is briefly described. In Section 3 we summarize our method of calibrating the probe for ion temperature measurements by means of PIC simulations. In Section 4 the experimental set-up of the STP prototype at the CASTOR tokamak is

* Corresponding author.

E-mail address: panek@ipp.cas.cz (R. Pánek).

addressed, and the results obtained from the experimental testing of the STP are discussed.

2. The segmented tunnel probe

The STP consists of a hollow conducting tunnel a few millimeters in diameter and typically 5 mm deep, closed at one end by an electrically isolated conducting back plate. The tunnel axis is parallel to the total magnetic field. To repel electrons, the conductors are negatively biased. Originally [4] the tunnel probe was conceived to exploit the dependence of the magnetic sheath thickness on electron temperature to provide measurements of that quantity. The ions flowing into the tunnel orifice get unmagnetized by an intense radial electric field in the magnetic pre-sheath, and redistributed between the back plate and the tunnel, Fig. 1 (left). The tunnel-to-back-plate ion current ratio is therefore a function of electron temperature. The sum of the tunnel and the back plate currents divided by the cross section of the tunnel orifice gives the incident parallel ion current density, $J_{\parallel,i}$.

The axial distribution of ion flux onto the tunnel decays with a characteristic length scale that is determined by the relative strength of the radial acceleration with respect to the incident parallel ion velocity. The latter is a function of the ion sound speed. Therefore, in addition to the electron temperature and ion current density measurements, if we divide the tunnel into two segments, the ion temperature can also be obtained from the ratio of ion current to the first and the second segment, $R_c = I_{\text{seg1}}/I_{\text{seg2}}$.

To account for the influence of the plasma flows in the SOL, two tunnels are mounted back-to-back in a Mach probe arrangement, Fig. 1 (right), sampling plasma from both upstream and downstream directions along the total magnetic field. If the plasma flow is not too large, the measured parameters in question are calculated as an average of the upstream and downstream values [5].

The advantage is that the probe operates in DC mode and thus provides fast measurements of the above mentioned quantities. Moreover, due to clearly defined tunnel orifice, the STP is not subject to the uncertainties of collecting area from which classical convex probes suffer.

3. Particle-in-cell simulations of the STP

Particle-in-cell (PIC) simulations were used for the calibration of the probe for ion and electron temperature measurements. We used two-dimensional PIC code XOOPIC [6]. Due to the axial symmetry of the probe, the XOOPIC code can simulate the whole region inside the tunnel. In the simulations, Maxwellian electrons and ions with different combinations of temperatures ($T_{i,e}$) and current densities ($J_{\parallel,i,e}$) are injected into the simulation domain from the right hand boundary, Fig. 1 (left). The potential of the injection plane is held at 0 V. The probe is held at $V_{\text{bias}} - 3T_e$, where V_{bias} is the biasing potential of the probe, referred to the vessel ground. The code calculates the ion current collected by each segment which enables to evaluate the ratio R_c . It must be noted that the value of R_c does not depend only on T_i , but to some extent also

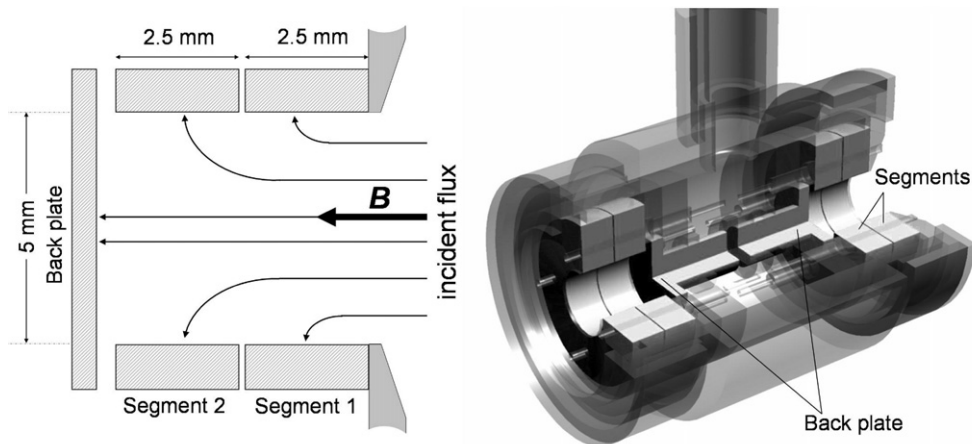

Fig. 1. Left: Scheme of the STP tunnel. The ion trajectories are shown by black arrows. Right: Schematic drawing of the probe head. Two segmented tunnels are mounted back-to-back in a Mach probe arrangement.

on electron temperature T_e and parallel ion current density $J_{\parallel,i}$. However, T_e is measured simultaneously from the tunnel-to-back-plate ion current ratio (see [4]). The sum of the tunnel segments and the back plate divided by the cross section of the orifice gives $J_{\parallel,i}$. Therefore, the ion temperature $T_i = T_i(R_c, T_e, J_{\parallel,i})$ is unambiguously determined by the variables measured by the same probe.

More than 100 simulations for typical values relevant for SOL conditions in the CASTOR tokamak have been performed, i.e. $J_{\parallel,i} = 1\text{--}6 \text{ kAm}^{-2}$, $T_e = 5\text{--}60 \text{ eV}$, $T_i = 5\text{--}60 \text{ eV}$.

From the simulation database we derived the analytical fitting formulae for T_i

$$T_i = 1.488 \cdot 10^2 + 2.539 \cdot 10^{-4} T_e^2 + 72.452 J_{\parallel,i}^{-1} - 37.51 R_c, \quad (1)$$

for $J_{\parallel,i} = 1\text{--}3 \text{ kAm}^{-2}$ and $V_{\text{bias}} = -200 \text{ V}$, and

$$T_i = 3.081 \cdot 10^2 + 0.347 T_e + 2.107 \cdot 10^2 J_{\parallel,i}^{-1} - 91.488 R_c, \quad (2)$$

for $J_{\parallel,i} = 3\text{--}6 \text{ kAm}^{-2}$ and $V_{\text{bias}} = -200 \text{ V}$.

Generally, the probe is able to measure the ion temperature approximately in the range $T_i \sim 5\text{--}100 \text{ eV}$, and plasma density n_e up to 10^{19} m^{-3} . However, detail study and optimization is under way now.

4. Experimental set-up and results

4.1. Experimental set-up

A prototype of the STP has been built and tested in the CASTOR tokamak (e.g. [7]). The ion currents collected by each segment and the back plate were measured separately with $1 \mu\text{s}$ time resolution. The tunnel axis was aligned with the local magnetic field in order to avoid magnetic shadowing by the tunnel that impedes ion flow to the back plate. As calculated from PIC simulations [8], the magnetic shadowing becomes an important factor only if the misalignment of the tunnel axis with respect to the magnetic field exceeds 5° . Such tolerances are easy to achieve, leaving a wide margin for variations of edge safety factor during the discharge.

The probe was installed on a manipulator located on the top of the torus, which could be displaced radially between discharges. A radial scan of the plasma parameters was performed on a shot-to-shot basis in successive reproducible discharges.

It is worth noting that the magnetic flux surfaces in the CASTOR tokamak need not to be concentric with its poloidal limiter. In the experiments described here, the magnetic axis was shifted downward by 2 cm with respect to the limiter, creating a secondary SOL at the top of the torus with the connection length of several toroidal turns (similar to the divertor or toroidal limiter tokamaks).

4.2. Radial profiles of the SOL plasma parameters in CASTOR

Using Eqs. (1) and (2), the radial profile of the ion temperature was constructed. Fig. 2 (top) shows a typical radial profile of ion and electron temperatures in CASTOR obtained from the STP, plotted against the minor radius, r . Each point is a result of averaging (of the upstream and downstream values) of the fluctuating plasma parameters over a few millisecond interval during a flat-top phase of the discharges. In addition, T_e from the STP is compared with similar measurements obtained from

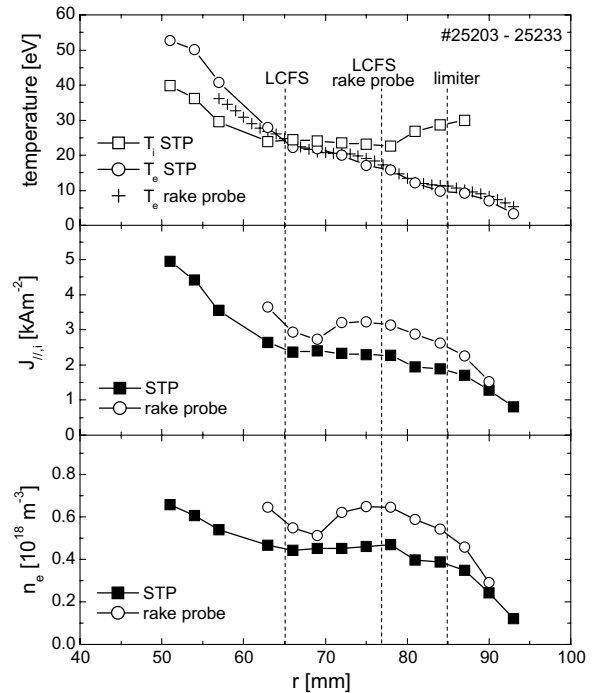

Fig. 2. Radial profiles of the ion and electron temperatures, parallel ion current density, and electron density (from top to bottom) in CASTOR measured by means of the STP and the rake probe. The position of the LCFS and the limiter is marked by a dashed line (note also that during the rake probe experiments the position of the LCFS was shifted towards the limiter).

the radial array of Langmuir probes (so called ‘rake probe’).

For $r < 65$ mm the ion temperature increases towards the plasma centre, but, as a consequence of the Ohmic-heating, T_e is higher than T_i . At $r_{\text{LCFS}} = 65$ mm T_i and T_e become comparable. In the region of $65 \text{ mm} < r < 85$ mm (i.e. between the LCFS and the poloidal limiter) the T_i profile flattens. Here the effect of the plasma pre-sheath starts to play role – the electron temperature further decreases while, in the second half of the region, the ion temperature increases slightly. At $r = 85$ mm the ratio of T_i/T_e approaches the value of ~ 3 . This is probably caused by volumetric power losses, impurity radiation, hydrogenic recycling, etc., which tend to strengthen the tendency for $T_i > T_e$. However, it might be also caused by the fact that the calibration breaks down at very low J_{\parallel} due to physical phenomena that XOOPIC simulations do not take into account (recycling etc.).

As seen from Fig. 2 (bottom), the values of plasma density n_e measured by the Langmuir probe are higher than the ones obtained from the STP. This is probably caused by the uncertainty in the rake probe effective collecting surface (taken as a simple geometrical projection of the probe tip), and consequent overestimation of the parallel ion current density, $J_{\parallel,i}$, Fig. 2 (middle). At the same time, it needs to be taken into account that during the rake-probe experiments the position of the LCFS was slightly shifted towards the limiter, which resulted in a higher plasma density.

4.3. Scaling of T_i and T_e with the plasma density

More direct evidence of the ion and electron temperature inequality in the SOL and its dependence on the plasma density was recently studied in CASTOR by means of the STP. In order to scale T_i and T_e with n_e , a series of discharges with monotonically decreasing density was performed. In these experiments, an additional gas puff was switched off, so that the plasma density decreased steadily during the discharge, with the line averaged density \bar{n}_e varying in the range of $1.4 \rightarrow 0.3 \times 10^{19} \text{ m}^{-3}$. Fig. 3 (top) shows a typical example of the temporal evolution of \bar{n}_e measured by the interferometer over a central chord, and the plasma density n_e obtained from the STP, positioned at $r = 80$ mm.

In Fig. 3 (bottom), ion and electron temperatures, simultaneously measured by the STP, are plotted against the plasma density at the probe posi-

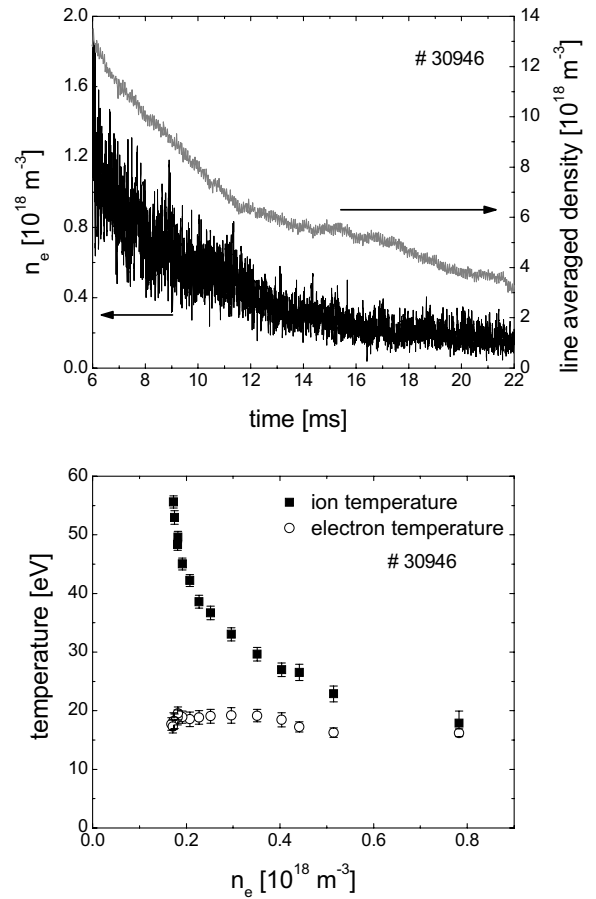

Fig. 3. Top: temporal evolution of the plasma density at the STP position and the line averaged density \bar{n}_e during the discharge with monotonically decreasing density. Bottom: scaling of T_i and T_e with the plasma density at the STP position, n_e . Each data point represents an average value for 1 ms of the discharge.

tion, n_e . Each data point represents an average value for 1 ms of the discharge. T_i falls roughly in proportion with $1/n_e$, while the temperature ratio T_i/T_e varies from ~ 3 at the lowest density to ~ 1 at $n_e \cong 0.8 \times 10^{18} \text{ m}^{-3}$, where T_i approaches the constant value. This is in a good qualitative agreement with the studies of $T_i(\bar{n}_e)$, performed by Matthews et al. [9], using an RFA and plasma ion mass spectrometer, PIMS.

5. Conclusions and summary

Complex electrostatic probes have been developed in the past decades for measurements of edge parameters not accessible with the simple Langmuir probes. This work describes a new such device, the segmented tunnel probe, and reports on its success-

ful application for simultaneous bi-directional measurements of ion temperature, electron temperature and parallel ion current density. This work focused on the measurements of ion temperature.

The operational principle of the probe is based on the magnetic pre-sheath effect in a hollow conducting tunnel. The STP operates in DC mode and thus provides fast measurements of the plasma parameters with the temporal resolution up to 1 μ s. This particularity gives the probe a significant potential to be employed in the research of transient phenomena (e.g. turbulence, fluctuations, ELMs).

We outlined the calibration of the STP by means of the 2-dimensional PIC code XOOPIC. Using the fitting formulae obtained from the PIC simulations, we reconstructed the radial profile of ion and electron temperatures, as well as the parallel ion current density and plasma density in CASTOR tokamak. Due to the pre-sheath effects in the SOL, the ion temperature was found to be considerably higher than T_e , which is in a good agreement with similar results reported in [10]. The temperature inequality in the SOL and its dependence on the plasma density was experimentally studied in detail in a series of discharges with monotonically decreasing density. The ion temperature scales roughly in proportion with $1/n_e$, while the electron temperature remains constant for the available density range.

Unfortunately, in the CASTOR tokamak, as well as in most of the other tokamaks, the edge ion temperature cannot be measured by any different method. Therefore, it is not possible to compare

our ion temperature profiles with the one obtained from a different diagnostic. However, simultaneous measurements of ion temperature by the STP are planned to be performed in the Tore Supra tokamak, equipped with the RFA probe.

To conclude, the segmented tunnel probe has already reached the level of technical performance at which it starts to provide a wide range of useful scientific results and can be experimentally tested in larger fusion facilities.

Acknowledgement

This work was supported by the Grant Agency of the Academy of Sciences of the Czech Republic Grant No. GAAV B100430602.

References

- [1] I. Katsumata, *Contrib. Plasma Phys.* 36S (1996) 73.
- [2] S.V. Ratynskaia, *Rev. Sci. Instrum.* 73 (2002) 12.
- [3] R.A. Pitts et al., *Rev. Sci. Instrum.* 74 (2003) 4644.
- [4] J.P. Gunn et al., *Czech. J. Phys.* 52 (2002) 1107.
- [5] F. Valasque, G. Manfredi, J.P. Gunn, E. Gauthier, *Phys. Plasmas* 9 (2002) 1806.
- [6] J.P. Verboncoeur, A.B. Langdon, N.T. Gladd, *Comp. Phys. Comm.* 87 (1995) 199.
- [7] J. Stockel et al., *Plasma Phys. Control. Fusion* 41 (1999) A577.
- [8] J.P. Gunn, *Phys. Plasmas* 8 (2001) 1040.
- [9] G.F. Matthews et al., *Nucl. Fusion* 31 (1991) 1495.
- [10] R.A. Pitts et al., in: *Proceedings of the 30th EPS Conference on Controlled Fusion and Plasma Physics*, ECA 27A, 2003, P-2.84.